

DOOR

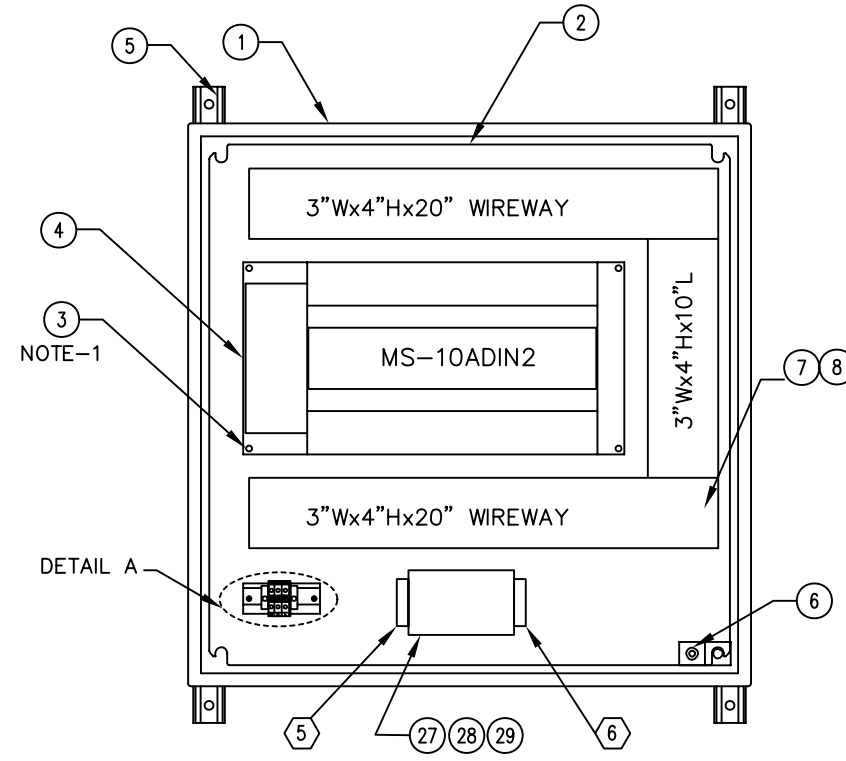

FRONT INSIDE

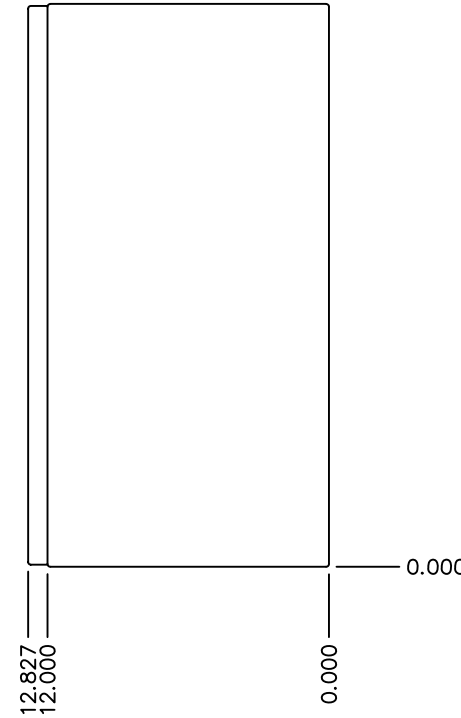

RIGHT SIDE

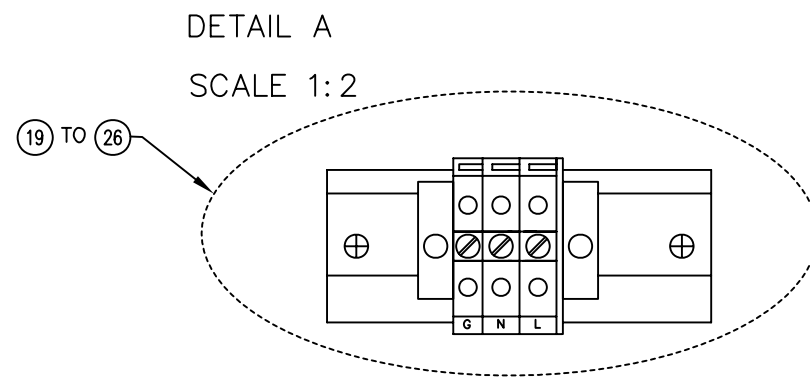

DETAIL A
SCALE 1:2

ITEM	QTY	PART NO.	DESCRIPTION
1	1	0911-0010	24"Hx24"Wx12"D NEMA-4 STEEL ENCL.
2	1	0913-0022	22.2"HX22.2"W BACK PANEL
3	1	2201-0009	MS CONTROLLER MOUNTING KIT
4	1	9001-0045	MS-10ADIN2 (D1-02-00)
5	1	0907-0001	STEEL ENCLOSURE MOUNTING KIT
6	1	0611-0002	GROUND LUG WIRE 4-0
7	6	1228-0031	3"Wx4"H PLASTIC GREY WIREWAY
8	6	1229-0015	3"W GREY WIREWAY COVER
9	2	1205-0003	#10-32 x 2" PAN PHILLIPS HD SCREW
10	2	1210-0005	#10-32 KEP NUT
11	0.25 FT	1901-0002	1/2" EMT CONDUIT
12	1	1004-0001	4" CABLE TIE
13	1	9003-0001_2	ML100-NS LOCAL DISPLAY
14	1	0607-0019	ML100 DISPLAY RIBBON CABLE 48"
15	1	1011-0017	RED ALARM LIGHT ASSEMBLY
16	21	1204-0007	8-32x0.375" PAN PHILLIPS HD SCREW
17	5	1227-0011	FLAT CABLE WIRE CLAMP & MOUNT
18	2	1227-0004	WIRE TIE SCREW MOUNT
19	2	0615-0003	WEID. SAK6N 47A/600VAC T.B.
20	1	0615-0013	WEID. EK4 36A/600VAC GND T.B.
21	1	0615-0052	WEID. AP/SAK4-10 END PLATE
22	2	0615-0053	WEID. EWK-1 END BRACKET
23	0.3 FT	0615-0091	TS32 STEEL MOUNTING RAIL
24	1	1406-0093	WEID. HORIZ T.B. MARKER L
25	1	1406-0094	WEID. HORIZ T.B. MARKER N
26	1	1406-0095	WEID. HORIZ T.B. MARKER G
27	1	0906-0008	LIGHT SWITCH BOX
28	1	0906-0009	LIGHT SWITCH COVER
29	1	0906-0006	LIGHT SWITCH

NOTES:

1. SEE DWG 509025-A0 FOR CONTROLLER MOUNTING DETAILS.
2. SEE DWG 508049-A2 FOR DISPLAY CUTOUT DETAILS.
3. HEATER WIRING REFER TO DWG 600094C1

REV	DESCRIPTION	DATE
AO	ORIGINAL	01-13-09

LABEL	QTY	COLOUR	SIZE	LABEL DESCRIPTION
6	1	1405-0008	2" X 0.5"	PANEL INTERIOR POWER SWITCH OFF
5	1	1405-0008	2" X 0.5"	PANEL INTERIOR POWER SWITCH ON
4	1	1405-0008	2" X 0.5"	LIGHT ON SYSTEM ALARM
3	1	1405-0007	4" X 2"	NEXTRON CORPORATION
2	1	1405-0007	4" X 2"	WARNING: POWER FROM MULTIPLE SOURCES
				AREA CLASSIFICATION: NON-HAZARDOUS AREA
				RATING: 120VAC/2A, 280VAC/30A MAX PER HTR, HTP
1	1	1405-0007	4" X 2"	MODEL: MS-10DIN2-E1D1-A1-SP
LABEL	QTY	COLOUR	SIZE	LABEL DESCRIPTION

LABEL SCHEDULE

		#14 6120 - 11th Street S.E. CALGARY, ALBERTA T2H 2L7 TEL: (403) 735-9555 FAX: (403) 735-9559	
CUSTOMER:		SCALE: 1:8	
DRAWING TITLE: 10-CIRCUIT HEAT TRACE PANEL		SHEET NO.: 1 OF 2	
DRAWING NAME: LAYOUT & FABRICATION		DRAWING NO.: 901691	
PRODUCT NAME: MS-10DIN2-E1D1-A2-FP-SP		REVISION: A0	
PART NO.: 9005-2561		DATE: 01-13-09	
ENGINEER: Y. ZENG		WORK ORDER NO.: N.A.	
CHECKED BY:		APPROVED BY:	
FILE: 901691A1.DWG		FORMS: TB_B4.DWG	

ITEM	QTY	PART NO.	DESCRIPTION
------	-----	----------	-------------

NOTES:

- HEATERS AND RTD's TO BE WIRED IN THE FIELD.
- TRANSIENT GND TERMINAL 123 IS REQUIRED FOR TRANSIENT PROTECTION CIRCUIT IN RTD INPUT TO WORK.
- MECHANICAL ALARM OUTPUT
 -ORDINARY AREA RATING: 120VAC/1A
 -HAZARDOUS AREA RATING: 30VDC/10mA

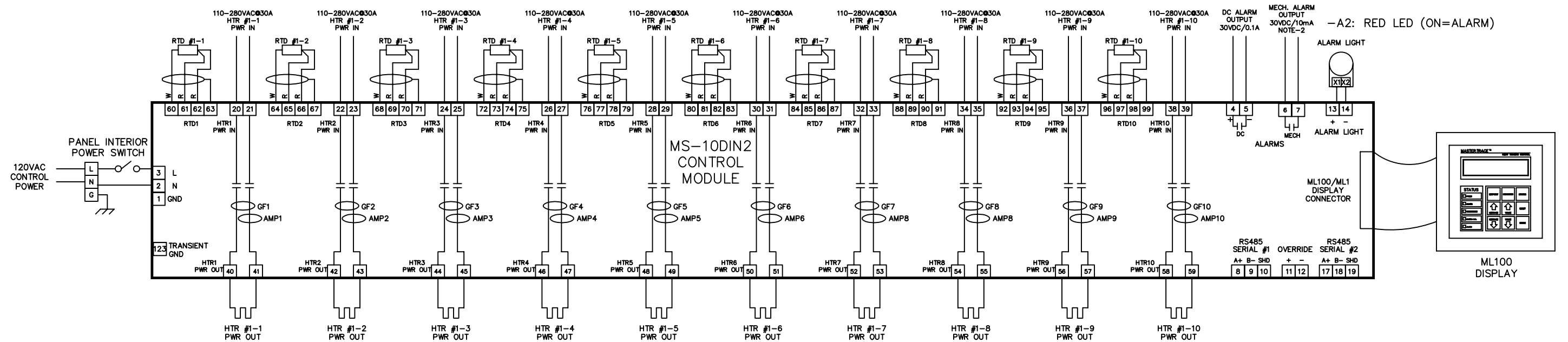

-A2: RED LED (ON=ALARM)

AO	ORIGINAL	01-15-09
REV	DESCRIPTION	DATE

LOCATION	DESCRIPTION	PART NO.	AWG	TYPE	COLOR	LENGTH (FT)
ALARM LIGHT	POSITIVE	0803-0007	18	TEW	RED	5
ALARM LIGHT	NEGATIVE	0803-0008	18	TEW	BLK	5
CONTROL POWER	GROUND	0803-0015	14	TEW	GREEN	5
CONTROL POWER	NEUTRAL	0803-0016	14	TEW	WHT	2
CONTROL POWER	LIVE-A	0803-0014	14	TEW	BLK	2

		#14, 6120 - 11th Street S.E. CALGARY, ALBERTA T2H 2L7 TEL: (403) 735-9555 FAX: (403) 735-9559	
CUSTOMER:		SCALE: NTS	
DRAWING TITLE: 10-CIRCUIT HEAT TRACE PANEL		SHEET NO.: 2 OF 2	
DRAWING NAME: WIRING DIAGRAM		DRAWING NO.: 901691	
PRODUCT NAME: MS-10DIN2-A2-FP-SP		DATE: 01-15-09	
ENGINEER: Y. ZENG		WORK ORDER NO.: N.A.	
CHECKED BY:		APPROVED BY:	
FILE: 901691A2.DWG		FORMS: TB_B4.DWG	